



**SCHMITT  
MEASUREMENT  
SYSTEMS, INC.**

A DIVISION OF SCHMITT INDUSTRIES, INC.

---



## **Auto-Collimating Laser Alignment System**

**ALMS 2002**

---

**Operator's Manual**

085-932-101

Revision 1 –15 January, 1999

## **PROPRIETARY NOTICE**

This manual contains information and specifications about (SMS) Schmitt Measurement Systems, Inc. products which are considered proprietary and is provided with the understanding that it be used under the following conditions:

1. The information is to be used expressly for installation, training, and operation of the specific equipment.
2. The information shall not be transferred or conveyed to third parties without the express written permission of Schmitt Measurement Systems, Inc.
3. Reproduction of this manual is not permitted without the express written permission of Schmitt Measurement Systems, Inc.
4. The information is subject to change without notice or prior approval.

## PREFACE

### **Purpose**

The purpose of this manual is to provide detailed information on the setup and operation of the SMS Model 2002 Auto-Collimating Alignment Laser System.

### **Comments/Suggestions**

Schmitt Measurement Systems, Inc. would be pleased if you would provide us with your comments, corrections, or suggestions relating to this manual or the Model 2002. Please send to:

Model 2002 - Manual Editor  
Schmitt Measurement Systems, Inc.  
2765 NW Nicolai  
Portland, Oregon 97210  
Phone: 503-227-5178  
FAX: 503-227-5040

### **Additional Copies**

For additional copies contact Schmitt Measurement Systems, Inc. and request Model 2002 Auto-Collimating Laser Alignment System Operators Manual, Part Number 085-932-101.

## TABLE OF CONTENTS

INTRODUCTION .....	1
Using this Manual .....	1
Safety Precautions.....	2
Liability Limit Notice.....	5
Unpacking.....	5
SYSTEM DESCRIPTION.....	6
General System Overview.....	6
Basic System Configuration .....	6
Auto-Collimating Alignment Laser .....	7
Power Supply.....	8
Digital Display.....	9
End Target.....	11
See-Thru Targets .....	12
Bus Box Connectors.....	12
NORMAL OPERATING PROCEDURES .....	13
System Configuration .....	13
System Alignment.....	15
Align the Work .....	17
Computer Operation .....	17
SYSTEM OPERATING LIMITS AND SPECIFICATIONS .....	20
Operating Limits .....	20
Specifications .....	20
Model Number Nomenclature.....	22
MAINTENANCE.....	23
Scope of Maintenance.....	23
Auto-Collimating Alignment Laser .....	23
Power Supply.....	23
Digital Display.....	23
Target .....	24
Bus Box Connectors.....	24
TROUBLE SHOOTING.....	25

## SECTION I

### INTRODUCTION

#### Using this Manual

This manual is intended to allow the operator to proceed step-by-step through system setup and operation of the SMS Model 2002 Auto-Collimating Alignment Laser System. To aid the reader in finding specific information, the manual has been divided into six sections.

- Section I**      General Information.
- Section II**     Component Description.
- Section III**    Normal Operating Procedures.
- Section IV**    Specifications and Operating Limits.
- Section V**     Maintenance.
- Section VI**    Trouble Shooting.

Carefully following the procedures outlined in this manual should answer most questions on how to setup and operate the system. If there are any questions regarding operation, do not hesitate to contact your sales representative or SMS directly.

To aid the reader in identifying important information relating to safety and proper operation, selected areas will be highlighted in the following manner.

#### **WARNING**

Information directly relating to operator health or safety will be identified within a WARNING block.

#### **CAUTION**

Information about possible damage to the system will be identified within a CAUTION block.

Information which is of special importance will be identified with the following symbols.



Special Attention



Electrical Shock Hazard



Optical Injury Hazard

### **Safety Precautions**

Before operating any portion of this instrument, it is recommended that personnel become familiar with the procedures outlined below.

1.



Electrical Shock Hazard

#### **WARNING**

The voltages and currents used in this equipment are potentially dangerous and normal precautions should be exercised when operating this equipment.

Before using any portion of this equipment it is recommended that the operator observe the following procedures.

- a. Do not allow any of the components to be placed in standing water.
- b. Insure that the power supply cord is connected to an AC source of the correct voltage and frequency. Equipment is supplied with a three-wire, grounding-type power cord. Connect only to a properly grounded three-wire receptacle.
- c. To prevent damage, insure that any extension cord is sized properly for its load and length.
- d. Locate power cords and bus cables where they will not become damaged.

- e. The Power Supply and Digital Display units generate heat in normal operation. When operating, do not restrict the free flow of air around the cases and do not place the cases on or near sources of heat.
- f. Always disconnect primary AC power from the equipment before performing any service or maintenance work.

2.



Optical Injury Hazard

**WARNING**

- ☐ The laser power source is enclosed in a specially designed housing to provide protection from inadvertent exposure to laser radiation. **DO NOT** attempt to perform any maintenance or disassembly of this tube.
- ☐ To avoid the risk of any possible exposure to harmful radiation, do not stare or look directly into the laser beam.
- ☐ Use of control or adjustments, or performance of procedures other than those specified herein may result in hazardous radiation exposure.
- ☐ If the Power Supply light is illuminated, laser power may be **ON** and radiating energy.

- a. All lasers are classified by the Center for Devices and Radiological Health, (CDRH) of the U.S. Food and Drug Administration and by ANSI Z-136. The classification philosophy is based upon human access and potential hazard.
- b. This equipment contains a Class II laser. Class II lasers do not have enough output power to accidentally injure a person unless the viewer overcomes the natural aversion to avoid looking directly at a bright light and continuously stares into the laser beam.
- c. Class II laser operation does not require any special devices for eye protection.
- d. This instrument is specifically designed to reduce concerns of using a Class II laser device. The laser source is enclosed in the laser tube assembly to reduce the possibility of stray laser radiation, the exit aperture is clearly marked, and a shutter safety cap is provided to prevent inadvertent radiation exposure.
- e. Maintenance beyond normal operating procedures should only be performed by factory authorized personnel.

- f. Warning labels (see Figures 1-1 and 1-2) have been attached to the laser tube to warn operators of areas that radiate laser power and to properly identify the classification of this equipment.

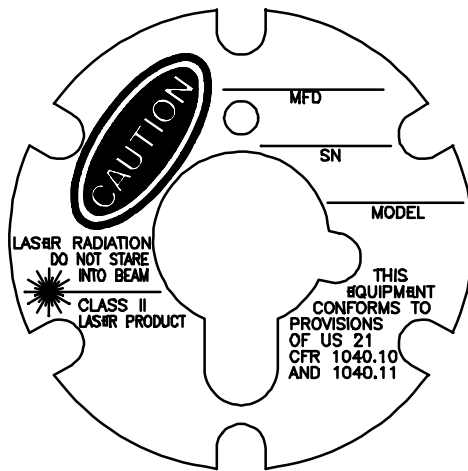
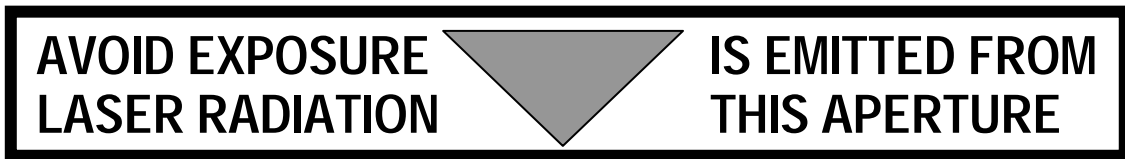

Figure 1-2. Laser Classification Label

3.



### Operating Precautions

Listed below are precautions which, if followed, will help reduce the hazard to other personnel in the area.

- a. Do not aim the laser beam at anyone's eye.
- b. Laser beam terminations should be used at the end of each laser path. If something other than a SMS target is used, beam-terminating material should be a diffuse reflector to optimize beam visibility and reduce the potential of reflections. Remove all unnecessary mirror like surfaces from within the vicinity of the laser beam path.
- c. Insure that bystanders do not position themselves in the path of any laser beam.
- d. The beam or its specular reflection should never be directly viewed with optical instruments such as binoculars or telescopes without appropriate protective filters.
- e. Turn off the laser when not in use or when left unattended.

### **Liability Limit Notice**

1. The procedures outlined in this manual are based on the best industrial information available at the time of publication, and if followed, will permit safe operation.
2. Schmitt Measurement Systems, Inc. will not be liable for any damage or injury arising out of failure to follow the instructions and cautions contained in this manual.
3. SMS will not be liable for failure to exercise due care and caution during the operation of this equipment.
4. SMS will not honor our warranty on any device that has been disassembled by anyone other than SMS authorized personnel.

### **Unpacking**

This instrument has been thoroughly inspected and carefully packed prior to shipment. If the packing container is damaged upon receipt, please notify Schmitt Measurement Systems, Inc. immediately.

Upon receipt and prior to removing the instrument from its shipping container, please verify that the shipping invoice compares with the original purchase order. When removing the instrument from the shipping container, compare the items received with the shipping invoice to insure that no error was made. If there is any discrepancy in either the order or the shipment, please contact SMS Shipping and Receiving Department immediately.

## SECTION II

### SYSTEM DESCRIPTION

#### **General System Overview**

The SMS Model 2002 Auto-Collimating Alignment Laser System is a lightweight, portable instrument designed for use in laboratory and industrial applications. The Model 2002 is one of the most advanced and accurate laser alignment systems commercially available. It incorporates a number of state of the art innovations designed to provide superior performance, reliability, and ease of use. The laser tube is constructed of specially hardened chrome plated stainless steel and utilizes a solid-state laser diode to improve beam stability and eliminate warm-up time. A digital electronic design incorporating a microprocessor allows the operator to automatically select up to seven targets. The universal digital bus network reduces setup time by allowing the connection of individual targets on the single bus network at any number of different locations. The digital bus network also reduces the number of cables needed for system operation. Individual targets contain preprogrammed target data thus allowing their movement to any location along the bus network. A specially designed See-Thru target completely eliminates beam displacement and power loss. The entire system is powered by either 110 or 220 volt AC through the Power Supply unit. The Digital Display unit has a large, easy-to-read LED display allowing measurement data to be viewed from long distances. The Digital Display unit also provides switches for selecting between the different targets or auto-collimation and offers the option of two dampening speeds.

#### **Basic System Configuration**

1. The SMS 2002 Auto-Collimating Alignment Laser System is designed around a single common digital bus network. All components share the same bus for power, control, and communications.
2. A basic system configuration (see Figure 2-1) is comprised of a power supply, laser, display unit, cabling, and at least one target.
3. The basic configuration can be varied by changing the cable lengths, adding bus box connectors, and inserting additional targets. Any number of bus boxes and cable lengths can be installed. The system can accommodate up to seven different targets at any one time and can be operated over a distance of 200 feet.
4. An RS 232 port on the rear panel of the display unit allows the system to be directly connected to a computer for controlling and storing all measurement data.

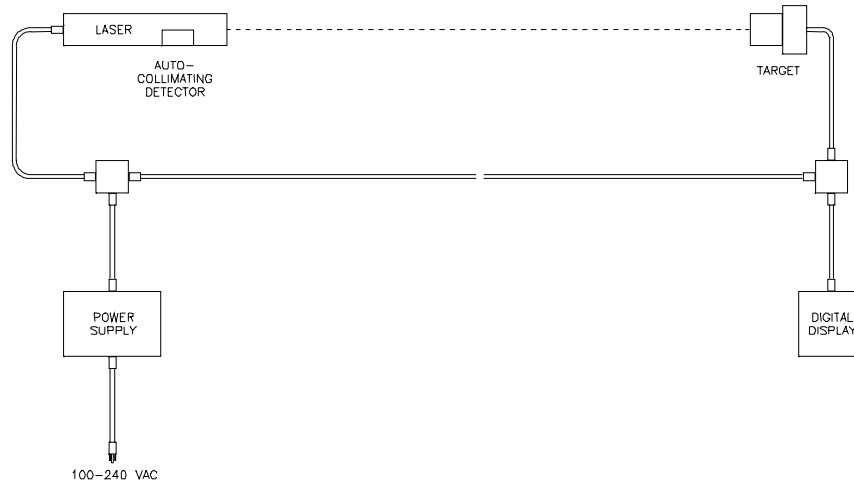
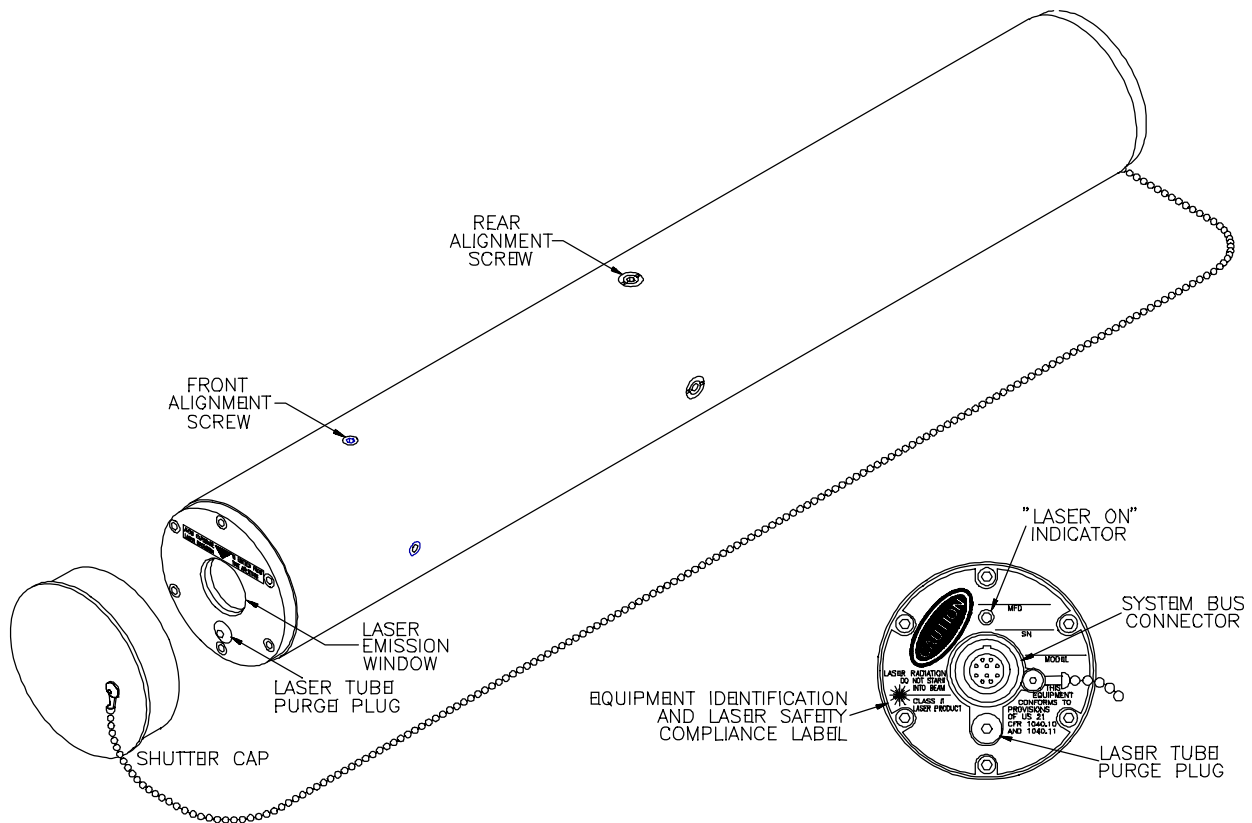

**Figure 2-1.** Basic System Configuration.

### **Auto-Collimating Alignment Laser**

1. The Auto-Collimating Alignment Laser (see Figure 2-2) is housed in a sealed, precision ground, chrome-plated stainless steel barrel, hardened to Rockwell C55. (See Section IV of this manual for specific details.) The interior of the tube is purged and filled with dry nitrogen gas to prevent fogging and oxidation of the internal components. The outer tube diameter conforms to NAS standards and will fit standard spherical adapters, mounts, and tooling holes.
2. The source for the alignment beam is a solid-state visible laser diode. The incorporation of a solid-state laser device essentially eliminates the need for system warm-up. The higher efficiency of laser diodes uses only a small fraction of the power of the older Helium-Neon gas discharge lasers and produces much lower levels of heat. This aids in maintaining beam stability. The overall result is a laser alignment source that is less sensitive to vibration and temperature variations than earlier gas-plasma lasers.
3. The laser beam is modulated at 5 kHz. This improves measurement accuracy and reduces sensitivity to ambient light. The power output of the laser diode is electro-optically regulated, providing a very stable beam.
4. Each laser tube has a built-in, auto-collimating detector for setting perpendicularity.
5. The visible wavelength of the laser provides the operator with an easy-to-see red beam that aids in system setup and adjustment. A red laser power ON light located on the rear of the tube indicates that the laser is operating.
6. A red safety shutter cap is provided to protect against inadvertent system radiation.

7. The laser is connected to the digital bus network by means of a quick disconnect electrical connector and cable. Any one of the supplied cables will operate between the laser and the Power Supply.
8. The entire laser tube assembly comes factory aligned and does not require any in-field adjustment.



**Figure 2-2. Alignment Laser.**

### **Power Supply**

1. The entire system is powered through an independent Power Supply unit (see Figure 2-3) by either external 110 or 220 volts AC. Each power supply is clearly marked indicating the correct voltage requirements (see Section IV of this manual for specific details).
2. The Power Supply has only one control located on the rear panel. The system can be turned on

or off using the power switch. Note: All power switches utilize the international symbol of "I" for ON and "O" for OFF.

3. A green indicator light on the front panel illuminates when the Power Supply is turned on.
4. Three standard bus connections are located on the rear panel allowing the laser, display, targets or bus network to be directly connected through the power supply.
5. The Power Supply unit can be positioned and connected at any location along the digital bus network and any cable can be plugged into any connector location.
6. A one-amp fuse is located in the rear panel and can be easily checked by removing the inspection cap. A spare fuse is also located in the fuse housing.

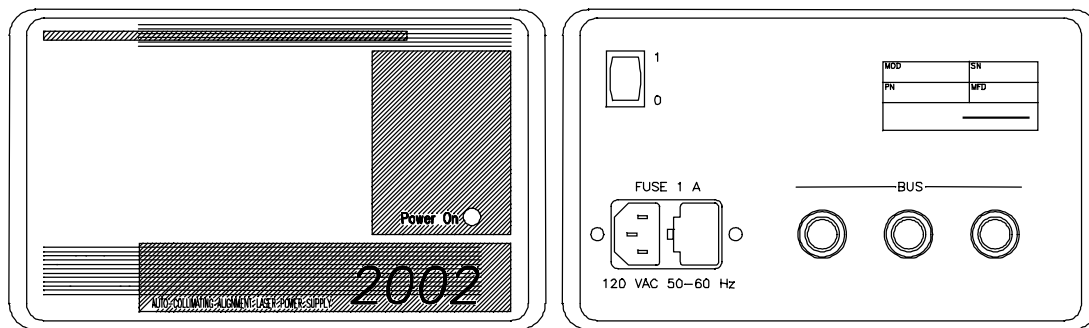

**Figure 2-3.** Power Supply Front and Rear Panels.

### **Digital Display**

1. The SMS 2002 Digital Display unit (see Figure 2-4) has a large display to show measurement readings and system information. The four digit red display is designed to be readily observable up to 30' away, even under the brightest industrial lighting conditions. (See Section IV of this manual for specific details.)
2. Two controls are located on the front panel.
  - a. The first control is a two-position selectable-dampening switch that allows the operator to set the display response time between fast and slow dampening. Selecting slow dampening increases the system response time and minimizes the effects of air turbulence, dust, and vibration.
  - b. The second control is a target select switch, which permits selecting one of up to seven different targets plus auto-collimation. An individual target can be selected by pressing either target select button (+ or -). The number in the target select window will correspond to the chosen target. The auto-collimating detector is operated by selecting target 0.

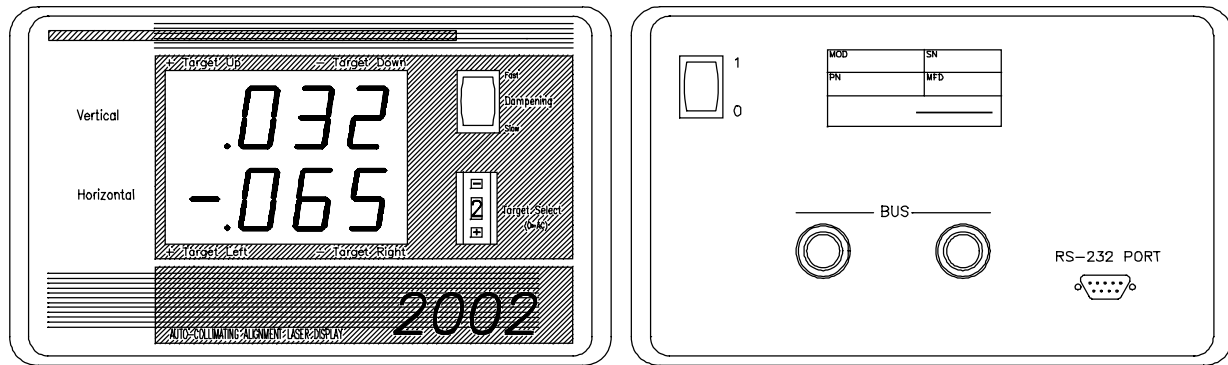

**Figure 2-4.** Digital Display Unit Front and Rear Panels.

3. The Digital Display unit is powered by connecting it to the digital bus network through either of the bus connectors located on the rear panel, and turning the power switch located on the rear panel to **ON**.
4. The display can be connected at any location along the system digital bus network and requires no additional external power source.
5. The front display window has two rows of four-character displays. The top row displays vertical measurement data and the bottom row horizontal measurement data. When providing measurement data the first digit in each row will only display a minus sign for negative values (plus sign for positive values is assumed). The readings are provided in thousandths of an inch or seconds of arc depending on the mode of operation. System messages are also displayed to inform the operator of the system status.
6. An RS-232 port is located on the rear panel for remote measurement control and data acquisition through a personal computer.
7. Error Codes. The following five error messages will be displayed on the front panel for the corresponding conditions.

Display	Meaning
<b>lo SgNl</b>	Low Signal
<b>ovEr LoAd</b>	Signal Overload
<b>----</b> <b>----</b>	Signal Out of Range
<b>no trGt</b>	Target Not Responding
<b>Err</b>	Divide by Zero Attempted

**End Target**

1. End Targets (see Figure 2-5) are each equipped with a 2 axis Position Sensitive Detector (PSD). These targets can be connected to the system through a bus box connector, Digital Display unit, or Power Supply. (See Section IV of this manual for specific details.)
2. Each target stores its own calibration data allowing targets to be freely moved within a system, or interchanged among systems.
3. Each End Target has an operator-selectable address switch located on the rear of the target. Targets can have addresses from 1-7. The address can be changed by using a small screwdriver and turning the switch to the desired location. Address 0 is reserved for auto-collimation and addresses 8 and 9 are reserved for special meter operations.
4. A green "target selected" light located on the front of the target will illuminate whenever that target is connected to the bus network and has been selected by the target selector switch on the display unit.
5. Each target is supplied with a removable light shield to protect the detector from damage and enhance beam discrimination.
6. The target-housing diameter conforms to NAS standards and requires no additional mounting tooling. To aid in holding the targets in position, two permanent magnets are mounted on the front of the target housing.
7. Vertical and horizontal reference marks are located on the rear data plate to aid in proper target orientation.

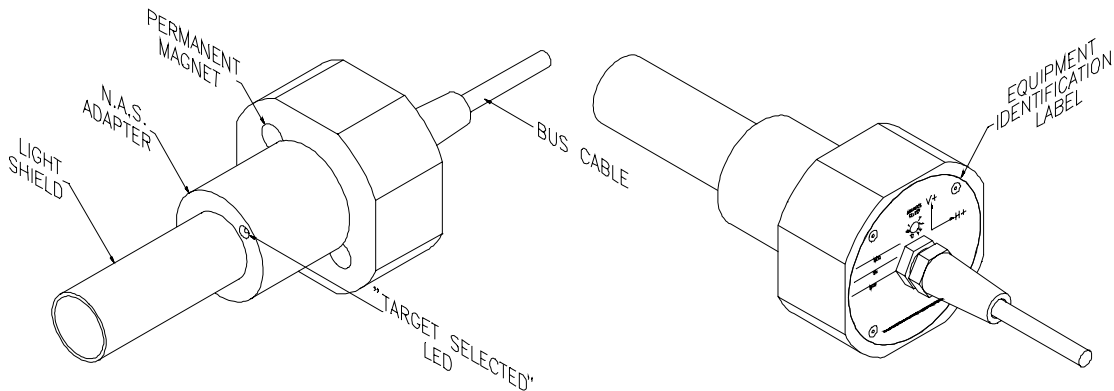

**Figure 2-5. End Target.**

### **See-Thru Targets**

1. The SMS 2002 See-Thru Targets (see Figure 2-6) are very similar to the End Targets described above. (See Section IV of this manual for specific detailed description.)

**Intentionally Blank**

**Figure 2-6.** See Thru Target

### **Bus Box Connectors**

1. The universal Bus Box (see Figure 2-7) is designed to connect the various components together using the standard cable connectors.
2. There are two versions of Bus Boxes. One type contains three connectors in which the cables or targets can be connected in any combination. The second type is hard-wired into the bus network and provides a single convenient connection point for other cables or targets.
3. The Bus Box allows the system to accommodate any number of different combinations of cable lengths or to vary the placement of Power Supply, Digital Display, Targets, or Laser without moving cables.

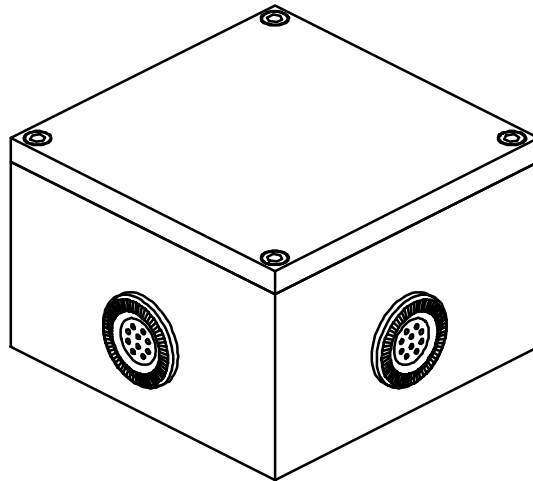

**Figure 2-7.** Bus Box Connector

## SECTION III

### NORMAL OPERATING PROCEDURES

#### System Configuration

1. Assemble all system components.
2. Determine location of Laser, Power Supply, Digital Display, and Targets.
3. Select appropriate combination of cables and Bus Box connectors.
4. Place Laser into appropriate mounting fixture and align in the desired direction of targets.



Insure that the shutter safety cap is in place on the front of the Laser to prevent inadvertent radiation.

5. Connect the Power Supply to the correct AC voltage source.

#### **CAUTION**

Applying incorrect voltage to the Power Supply could damage system electronics.



Insure that the power switch on the back panel of the Power Supply is **OFF** when connecting or disconnecting the unit to the network.

6. Connect the cables between the Power Supply and the Laser.

#### **CAUTION**

The system is protected when components are connected or disconnected from the digital bus. However to increase the service-life of the laser turn the Power Supply **Off** when disconnecting and connecting the laser to the system.

7. Position the targets in the appropriate fixtures with the white fiducial mark upward. Attempt to insure that the cable does not pull on the target or the target mount.



Prior to installing each target, note the setting of the target address selection number for each target. Individual target numbers may be changed by inserting a small screwdriver into the slot and selecting the desired target number.

8. Connect the targets and Digital Display to the bus network using the appropriate length cables and Bus Box connectors.

#### CAUTION

The system is protected when components are connected or disconnected from the digital bus. However to increase the service-life of the Targets turn the Power Supply **Off** when disconnecting and connecting the Targets to the system.



Insure that the power switch on the Digital Display is **OFF** when connecting or disconnecting the unit to the bus network.

9. Once the system has been configured turn **ON** the power switch located on the rear panel of the Power Supply unit. (Note the illumination of the green light on the front panel.)



Illumination of the light only indicates that power has been applied to the Power Supply and does not necessarily indicate that power has been applied to the entire system.

10. Turn **ON** the power switch located on the rear panel of the Digital Display unit.



Without valid target information the Digital Display will show a series of dashed lines.

11. Check that the red LED on the rear of the Laser is illuminated indicating that the laser is operating and remove the shutter safety cap.



Prior to removing the safety cap, insure that no one is in the path of the laser beam.

12. Select the desired target number and dampening rate on the front panel of the Digital Display.
13. Insure that the green LED on the selected target is illuminated.

## System Alignment

Many different setup configurations are possible, but each will fall into one of two general categories. Either the Laser is set as the reference, and the work is aligned to the Laser or the existing work is the reference, and the Laser is aligned to the work.

1. **The Laser as Reference.** The placement and alignment of the Laser establishes the reference line. Targets, affixed to work pieces, are aligned to the Laser reference line by moving the work piece.
  1. Move the work piece until the Laser spot is approximately centered in the detector window of the Target.
  2. On the Digital Display, use the **Target Select** switch to select the number of the Target to be measured. Check that the green "Target Selected" indicator light on the target illuminates. Read the displacement of the work piece from the reference line in thousandths of an inch directly from the Digital Display. Lack of a negative (-) sign indicates the positive direction.
  3. Move the work piece until the Digital Display shows **.000** or is within the acceptable tolerance for the Horizontal and Vertical axis. The work piece is now aligned to the reference line.

**The Work as a Reference.** An existing reference line can consist of a point and a direction, or two points.

1. **Aligning the Laser to two reference points.**

1. Set the Laser approximately in line with the two reference points.
2. On the Digital Display, use the **Target Select** switch to select the far Target. Rotate on to Target.
3. Select the near Target. Translate 1/2 the error past the near target. Note the measurement.
4. Remove near target, rotate on far target, read target.
5. Repeat Steps 2, 3, and 4, until the error becomes zero. The Laser is now aligned to the two reference points.

2. **Aligning the Laser to a reference point and perpendicular to a surface.**

1. Set the Laser approximately perpendicular to the surface at the reference point.

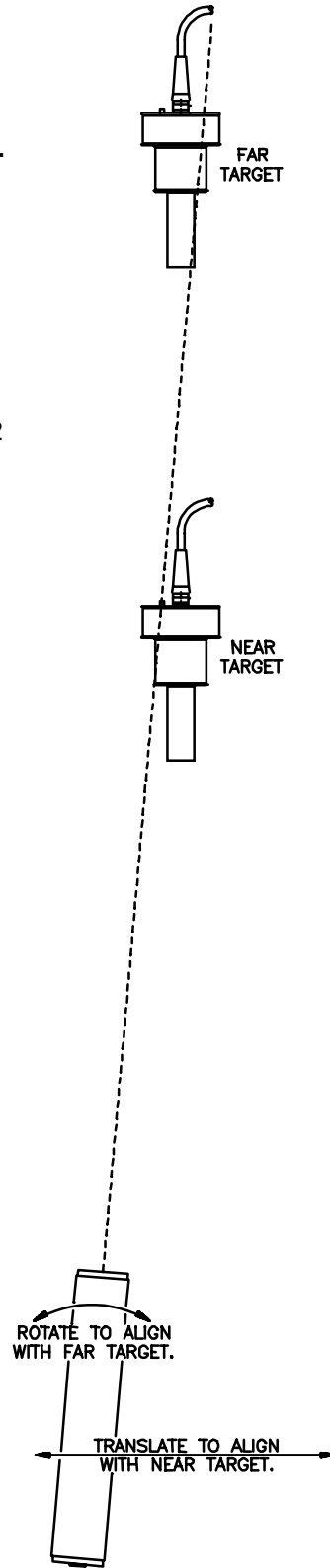

**Figure 3-2.** Aligning the laser.

2. Install a Laser Beam Finder Screen on the front of the Laser. A small piece of white paper with a hole in the middle can be substituted, if necessary.
3. Install a mirror at the reference point parallel to the reference surface.
4. Translate and rotate the Laser so that the reflected beam returns through the hole in the Laser Beam Finder Screen. Remove the mirror from the Target.
5. On the Digital Display, use the **Target Select** switch to select the Target. Note the measurement. Translate the Laser to place the beam at the center of the Target (both vertical and horizontal readouts indicate **.000**).
6. Mount a mirror on the Target. On the Digital Display, select the Auto-Collimating Detector, Target **0**. The values on the Digital Display are read directly in seconds of arc. Note the measurement. Rotate the Laser to reduce the angle to zero. Remove the mirror.
7. Repeat Steps 5 and 6 until both errors are zero. The Laser is now aligned to the reference point, and is normal to the reference surface.

### **Align the Work**

Once the Laser has been set to the reference line, additional work pieces or parts of the work can be aligned to the Laser. Targets can be selected in any order, and aligned in any order that may be required by the job.

1. Move the work piece or fixture until the Laser spot is approximately centered in the detector window of the Target.
2. On the Digital Display, use the **Target Select** switch to select the number of the Target to be measured. Read the displacement of the work piece from the reference line directly from the Digital Display.
3. Move the work piece until the Digital Display shows **.000** for both Horizontal and Vertical. The work piece is now aligned to the reference line.
4. Repeat as needed until all Targets are aligned.

### **Computer Operation**

Many types of computers and terminals may be connected to the RS-232 port on the rear panel of the Digital Display to provide automated or remote measurement and data acquisition capabilities. The system has been designed to provide the greatest degree of flexibility and compatibility, while retaining ease of operation.

1. **Communications Protocol.** The interface port on the Digital Display uses a simplified form of the RS-232 communications standard. Only the **XMIT**, **RCV**, and **GND** lines are used. Most commercial terminal software will work with the Digital Display. Set the parameters as follows:

Word Length: 8 bits  
 Parity: None  
 Stop Bits: One  
 Data Rate: 9600 Baud  
 Flow Control: None (No Handshaking)

2. **Command Set.** Valid commands for the Digital Display are listed below. Commands must be entered as all upper case and terminated with a **<RET>**.

<u>Command</u>	<u>Result</u>
LOCAL	Sets the Digital Display to respond to its front panel switches. When LOCAL operation is enabled, the TARGET and DAMPENING parameters are given the values set by the front panel switches, regardless of any previous values set during REMOTE operation. Returns * <b>LOCAL MODE&lt;RET&gt;</b> .
REMOTE	Disables the front panel switches, and sets the Digital Display to accept the full command set from the Computer. When REMOTE operation is enabled, the TARGET and DAMPENING parameters are given the front panel settings as their initial values. Returns * <b>REMOTE MODE&lt;RET&gt;</b> .
SLOW	Selects <b>Slow</b> Dampening time constant. Returns * <b>SLOW DAMPENING&lt;RET&gt;</b> .
FAST	Selects <b>Fast</b> Dampening time constant. Returns * <b>FAST DAMPENING&lt;RET&gt;</b> .
TARGET <n>	The parameter <i>n</i> must correspond to the address of a target connected to the bus. Values must be in the range <b>0-31</b> . If the parameter <i>n</i> is omitted, the Digital Display interprets the command as a query, and returns the number of the current target as <b>TARGET = n</b> .
MEAS	Requests current measurement data for the current target. Returns either data, in the format given below, or an error message.
VER	Returns the software version installed in the Digital Display, in the format <b>M1.00&lt;RET&gt;</b> .
SELFTEST	Initiates a complete test of the Digital Display microprocessor, memory, communications ports, front panel switches, and displays. A series of messages are returned, indicating the progress of the self-test routine and the results at each step. The format of the intermediate return messages consists of an algebraic sign followed by a short description of the test. The <b>+</b> indicates the test was passed without error. A <b>-</b>

indicates the test failed. After the last test is completed, a framing message is returned.

+ RS232 OK<RET>  
+ SRAM OK<RET>  
+ EEPROM READ OK<RET> or  
- EEPROM READ ERROR<RET>  
+ EEPROM WRITE OK<RET> or  
- EEPROM WRITE ERROR<RET>  
+ DISPLAY TEST STARTED<RET>  
+ DISPLAY TEST COMPLETE<RET>  
\* SELFTEST COMPLETE<RET>

Note: Though highly unlikely, it is possible to accidentally enter a protected diagnostic mode. In this case, the front panel will display **FLo thru**. To exit this mode, simply operate any front panel switch or send <RET>.

3. **Data Output.** In response to a **MEAS** command, the Digital Display will return two numeric values, corresponding to the position of the current target. For target **0**, the auto-collimation target, the format is  $\pm xxx.x, \pm yyy.y<RET>$ . For targets **1-31**, the format is  $\pm .xxxx, \pm .yyyy<RET>$ . Note that computer operation provides one more significant digit than is normally displayed on the front panel of the Digital Display.
4. **Error Messages.** The Digital Display sends error messages to the computer or terminal to notify the operator of an undefined mode of operation.

<u>Error Message</u>	<u>Cause</u>
* <b>COMMAND NOT RECOGNIZED</b>	Any command or character not listed above in the <b>Command Set</b> .
* <b>BAD TARGET</b>	The parameter with the <b>TARGET</b> command is out of the range <b>0-31</b> , or a target with the corresponding address is not connected to the bus, or is not responding.
* <b>LOW SIGNAL</b>	The signal level received by the selected target is too low for meaningful measurements.
* <b>TARGET OVERLOAD</b>	The signal level received by the selected target is so large that it overloads the signal processing electronics.
* <b>OUT OF RANGE</b>	An error has occurred during calculation of the target position, indicating that the target is outside its normal measurement range.

## SECTION IV

### SYSTEM OPERATING LIMITS AND SPECIFICATIONS

#### Operating Limits

##### MODEL 2002 SYSTEM

Temperature Range		
Operating		TBD
Storage	TBD	
Humidity Range		
Non-condensing		0 to 100%

#### Specifications

##### Laser

Dimensions		
Diameter		2.2498" to 0.0 - 0.0003 (NAS Standard)
Length		15"
Weight		12 lbs.
Output Power		700 $\mu$ W RMS
Modulation		100% AM at 5 kHz.
Wavelength		670 nm
Laser Life		> 10,000 hours
Alignment Range		200 ft.
Auto-Collimating Range	100 ft.	
Beam Diameter	0.3 in. at exit aperture	
Beam Concentricity		$\pm$ 0.001 in.
Beam Parallelism		$\pm$ 2 arc second

Auto-Collimating		
Angular Measurement	$\pm$ 10 arc seconds at 100 ft.	
Range		
Angular Resolution	$\pm$ 1 arc second (display limited)	
Angular Accuracy	$\pm$ 1 arc second	

##### Power Supply

Dimensions		5" h x 8 1/4" w x 7 1/8" d
Weight		9 lbs
AC Input Voltage		100 to 120 Volts AC or 220 to 240 Volts AC (Factory Selected)
AC Input Frequency		47 to 63 Hz
AC Input Power	30 Watts	
Power Dissipation		10 Watts Max

Specifications good over 8 hours at constant air temperature. Beam measured at output of laser and at 17 feet away.

**Digital Display**

Dimensions	5" h x 8 1/4" w x 7 1/8" d
Weight	4 lbs.
Type	4 digit, 7 segment LED
Color	Red, 630 nm
Range	± 999 x 0.001 in., ± 999 arc seconds
Detector Selector	Push-wheel Switch, 0-7 (8 detectors)
Update Rate	2 Hz
Serial Interface	RS-232, 9 Pin D Connector

**See-Thru Target**

Mounting Ring	2.2498" + 0.0 - 0.0003 (NAS Standard)
Dimensions	TBD
Weight	TBD
Detector	
Range	TBD
Resolution	TBD
Accuracy	TBD

**End Target**

Mounting Ring	2.2498" + 0.0 - 0.0003 (NAS Standard)
Dimensions	3 3/8 Dia x 7 1/2 Long
Weight	3 lbs.
Detector	
Range	± 0.150 in.
Resolution	± 0.001 in. (Display Limited)
Accuracy	± 0.001 in.

**Bus Box**

Dimensions	1 11/16"h x 2 5/8"w x 25/8"d
Weight	.5 lbs
Connectors	4
Cables	
Length	10 ft., 50 ft., 100 ft., 200 ft.
Weight	5.5 lbs./100 ft.
Type	Extra Flexible, PVC Insulated
Outside Diameter	0.30 in.

### **Model Number Nomenclature**

<u>Model #</u>	<u>Individual Items</u>
ALL-1	Laser
ALPS-1	Power Supply
ALDD-1	Digital Display
ALST-1	See-Thru Target (with 10' pigtail)
ALET-1	End Target (with 10' pigtail)
ALBB-1	Bus Box (with 4 connectors)
ALC-10	10' Cable
ALC-20	20' Cable
ALC-50	50' Cable
ALC-100	100' Cable
ALC-200	200' Cable
ALCA-100	100' Cable Assembly (w/5 bus boxes)
ALCC-1	Carrying Case
ALCK-1	Calibration kit
ALOM-1	Operators Manual

## **SECTION V**

### **MAINTENANCE**

#### **Scope of Maintenance**

The SMS Model 2002 Auto-Collimating Alignment Laser System is designed so that it does not require maintenance beyond external cleaning and infrequent calibration. (Calibration can be performed by a factory trained service technician or with a Calibration Kit purchased from SMS.)

Since there are no user serviceable components, the operator should not attempt to open any of the Model 2002 components. Attempts to open any of the components will void the warranty.

#### **Auto-Collimating Alignment Laser**

The Auto-Collimating Alignment Laser requires only cleaning and an occasional calibration. The chromed Laser barrel can be cleaned with a mild cleanser such as a window cleaner. Methanol or acetone can be used to clean particularly pesky stains. The exit aperture window can be cleaned with a methanol dampened lens tissue. At no time should the front cap, rear cap, or any of the screws be removed because this may cause the Laser to become misaligned or the dry nitrogen environment might be compromised. Any such action will void the warranty. The connector on the back should be occasionally blown out with compressed air to remove dust and debris.

Calibration can be performed by a SMS trained technician or by a trained operator with the aid of a SMS Calibration Kit. Calibration is described in the Calibration Kit Operators Manual.

#### **Power Supply**

The exterior of the Power Supply can be cleaned with mild detergent such as a window cleaner or a household kitchen cleaner. Dust and debris can be removed from the three bus connectors on the back panel by blowing compressed air on them. There are no user serviceable components in the Power Supply with the exception of a fuse. Any attempt to open the Power Supply will void the warranty. This fuse and a spare are accessible by removing the fuse drawer, which is located next to the power cord receptacle on the back panel.

#### **Digital Display**

A mild detergent or household cleaner should be used to clean the exterior of the Digital Display. Compressed air can be used to blow dust and debris from the two bus connectors, which are located on the back panel. There are no user serviceable parts in the Digital Display; therefore, the user should not attempt to open the Digital Display. Any such action will void the warranty.

## **Target**

A mild detergent or household cleaner can be used to clean the exterior of the Target. Clean, dry air can be used to remove dust and debris from the detector element. A methanol dampened lens tissue can be used to remove fingerprints or greasy stains from the detector face. There are no user serviceable parts in the Target; therefore, the user should not attempt to open the Target. Any such action will void the warranty.

The target should have its calibration checked every time the Laser is calibrated. The can be done by a SMS trained technician or by a trained operator with the aid of a Calibration Kit.

## **Bus Box Connectors**

A mild detergent or household cleaner should be used to clean the exterior of the Bus Connector. Compressed air can be used to blow dust and debris from the three bus connectors on the box. There are no user serviceable parts in the Bus Box Connector; therefore, the user should not attempt to open the box. Any such action will void the warranty.

## SECTION VI

### TROUBLE SHOOTING

Symptom	Possible Cause
1. Power Supply indicator fails to light.	<ol style="list-style-type: none"> <li>1. Power cord not connected, or loose. Check connections at both ends of cord.</li> <li>2. Rear panel power switch <b>off</b>. Turn power switch <b>on</b>.</li> <li>3. Rear panel fuse blown. Replace with spare. If the second fuse blows, disconnect from AC mains and refer to Service Depot.</li> <li>4. Power indicator may be burned out. Even if all other functions appear normal, refer to Service Depot, as the power indicator is a vital safety device.</li> </ol>
2. Power Supply case is very hot or emits smoke.	<ol style="list-style-type: none"> <li>1. Digital Bus Network is overloaded with too many Targets and/or too many Digital Displays. Up to 7 Targets and 2 Digital Displays are allowed.</li> <li>2. Digital Bus Network cables may be damaged. Replace kinked, cut, or crushed cables.</li> <li>3. A defective Laser, Digital Display, or Target is connected on the Digital Bus Network. Disconnect the suspected unit, or substitute a like unit of known condition, and recheck the Power Supply.</li> <li>4. Power Supply is defective. Refer to Service Depot for evaluation and repair.</li> </ol>
3. Digital Display appears dead (no activity on front panel).	<ol style="list-style-type: none"> <li>1. Power Supply not <b>on</b>. Check that Power Supply is operating correctly.</li> <li>2. Digital Display not connected to Digital Bus Network, or cable not properly connected. Check all Digital Bus Network cables, including Bus Boxes, if any.</li> <li>3. Digital Display rear panel power switch <b>off</b>. Turn power switch <b>on</b>.</li> </ol>
4. Digital Display shows <b>lo SGNL</b> .	<ol style="list-style-type: none"> <li>1. Beam from Laser partially obstructed. Check path.</li> <li>2. Beam path too long. Maximum range for End Target is 200 feet. Maximum range for auto-collimation is 100 feet.</li> <li>3. Laser output window dirty. Carefully clean with methanol.</li> <li>4. Target detector window dirty. Remove light shield and carefully clean with methanol. Replace light shield.</li> <li>5. Laser output level low. Refer to Service Depot for evaluation and repair.</li> </ol>
5. Digital Display shows <b>ovEr LoAd</b> .	<ol style="list-style-type: none"> <li>1. Laser output level high. Refer to Service Depot for evaluation and repair.</li> <li>2. Extraneous light reaching detector. Check that Target light shield is firmly in place. Check for other light sources, including the sun, which may be shining along beam path.</li> </ol>

6. Digital Display shows ---- ----.	<ol style="list-style-type: none"> <li>1. Beam is not in central portion of detector. Coarsely align Target so that beam falls on central portion of detector, a 3/4-inch circle.</li> <li>2. Beam is obstructed. Check path.</li> <li>3. Beam path too long. Maximum range for End Target is 200 feet. Maximum range for auto-collimation is 100 feet.</li> <li>4. Laser output window dirty. Carefully clean with methanol.</li> <li>5. Target detector window dirty. Remove light shield and carefully clean with methanol. Replace light shield.</li> <li>6. Laser output level low. Refer to Service Depot for evaluation and repair.</li> </ol>
7. Digital Display shows <b>no trGt.</b>	<ol style="list-style-type: none"> <li>1. No Target with selected number is connected to Digital Network Bus. Check <b>Address Select</b> switch on Target. Check Target connecting cable. Check Digital Network Bus connections.</li> <li>2. Defective Target. Select a Target of known condition. Refer defective Target to Service Depot for evaluation and repair.</li> </ol>
8. Digital Display shows <b>Err.</b>	<ol style="list-style-type: none"> <li>1. An internal divide-by-zero error has occurred. Beam is not in central portion of detector. Coarsely align Target so that beam falls on central portion of detector, a 3/4 inch circle.</li> <li>2. Defective Target. Select a Target of known condition. Refer defective Target to Service Depot for evaluation and repair.</li> </ol>
9. Digital Display shows <b>fLo thru.</b>	<ol style="list-style-type: none"> <li>1. A protected diagnostic mode has been entered. Restore normal operation by operating any front panel switch or sending <b>&lt;RET&gt;</b> to the RS-232 port.</li> </ol>
10. Laser <b>on</b> indicator not lit.	<ol style="list-style-type: none"> <li>1. Digital Network Bus cable not connected, or loose. Check connections at both ends of cable.</li> <li>2. Power Supply <b>off</b>. Turn power switch <b>on</b>.</li> <li>3. Laser <b>on</b> indicator may be burned out. Even if all other functions appear normal, refer to Service Depot, as the Laser <b>on</b> indicator is a vital safety device.</li> </ol>
11. Laser not emitting beam.	<ol style="list-style-type: none"> <li>1. Laser safety shutter is blocking beam. Check shutter.</li> <li>2. Laser output window dirty. Carefully clean with methanol.</li> <li>3. Laser defective. Substitute a Laser of known condition. Refer defective Laser to Service Depot for repair.</li> </ol>

12. Laser beam is weak, distorted, or pointing off centerline.	<ol style="list-style-type: none"> <li>1. Laser output window dirty. Carefully clean with methanol.</li> <li>2. Laser defective. Substitute a Laser of known condition. Refer defective Laser to Service Depot for repair.</li> </ol>
13. Auto-collimating detector gives erratic measurements.	<ol style="list-style-type: none"> <li>1. Beam path is introducing optical noise with airborne dust, changing air density (hot and cold), or relative movement of Laser and reflector. Switch to <b>Slow</b> dampening. Eliminate noise sources.</li> <li>2. Laser output window dirty. Carefully clean with methanol.</li> <li>3. Reflected signal near minimum usable. Check condition of reflector and path length. Eliminate sources of beam attenuation, such as airborne dust.</li> <li>4. Laser defective. Substitute a Laser of known condition. Refer defective Laser to Service Depot for repair.</li> </ol>
14. <b>Target Selected</b> lamp does not light on End Target.	<ol style="list-style-type: none"> <li>1. Target cable not connected, or loose. Check connections.</li> <li>2. Target address and Digital Display <b>Target Select</b> do not match. Check Target <b>Address Select</b> switch to insure that its setting is unique within the system. Check setting of Digital Display <b>Target Select</b> switch to insure that it matches the address of the Target.</li> <li>3. <b>Target Selected</b> indicator may be burned out. Even if all other functions appear normal, refer to Service Depot, as the <b>Target Selected</b> indicator is important to operation.</li> </ol>
15. End Target gives erratic measurements.	<ol style="list-style-type: none"> <li>1. Beam path is introducing optical noise with airborne dust, changing air density (hot and cold), or relative movement of Laser and Target. Switch to <b>Slow</b> dampening. Eliminate noise sources.</li> <li>2. Laser output window dirty. Carefully clean with methanol.</li> <li>3. Received signal near minimum usable. Check path length. Eliminate sources of beam attenuation, such as airborne dust.</li> <li>4. Target defective. Substitute a Target of known condition. Refer defective Target to Service Depot for repair.</li> </ol>